



## Goedhart VCI

Industrial air coolers for cooling & freezing applications

Cu/Al

R404A - CO<sub>2</sub>



# Goedhart VCI

The extensive range Goedhart VCI single discharge ceiling mounted industrial air coolers are available with capacities between 2,8 and 264,4 kW. The Goedhart VCI air coolers are suitable for cooling and freezing applications and with a wide variety of accessories and options available. The coil block is standard build from aluminium end plates, copper tubes and aluminium fins. The fans are arranged for blow-through air configuration for the Goedhart VCI-B and draw-through for the Goedhart VCI-Z (please state which is required when ordering).. The modular design incorporates 5 different sizes of fan, with model options of up to 8 fans per cooler.

## Type description

### Goedhart VCI-B 62567

B=blow through  
Z=draw through

Number of rows deep  
Number of fans  
Fan diameter [cm]  
Fins spacing [mm]

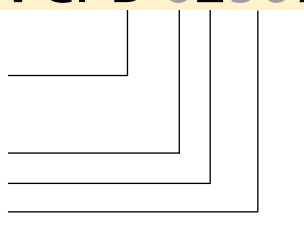

## Coil block

- Tube pitch : 50x50 mm straight
- Fin spacing : 4, 6, 7, 8, 10 and 12 mm
- Material : 15mm o.d copper tube
- : aluminium HT-lamellen
- Optimized cooling circuits
- Standard refrigerant connections are positioned on the left hand side of the unit when looking with the direction of the airflow.
- A good thermal contact is achieved by expansion of the tubes into the fin collars, that are also utilised as spacers to provide a constant distance between the fins.
- All coolers are pressure tested to 30 bar (lower by cooling mediums) and are supplied with a light over pressure charge of dry nitrogen.
- Suitable for all known refrigerants and coolants, with the exception of NH3.

## Casing

- Construction for ceiling mounting
- The flush mounting protects against and prevents accumulation of dust and dirt.
- Casing material of galvanized sheet steel
- Finishing is standard white epoxy spray (RAL 9003)
- Bend/header projection by end covers, easy removed for maintenance
- Defrost by hot gas spiral or electric defrost elements will be fixed to the bottom side of the coil.
- Stainless steel fasteners

# General range features

## Capacity

The listed nominal cooling capacities are based on R404A, DT1, RH of 85% and 4 pole 3 phase fans connected in Δ.

### Influence of Coating on Capacity

The use of coated fins, or of a fully coated coil will result in a capacity decrease of approximately 3%

### Capacity optimisation

Since Goedhart tries to limit stock products, we are capable of optimising the circuitry of our evaporators. In order to do this, the following information is needed :

- Design capacity
- Air volume
- Refrigerant
- Air on temperature
- Evaporating temperature
- Liquid temperature before expansion valve.

## Sound data

The mean sound pressure (LpA @ 3m ± 2 dB (A)) each air cooler is a calculated indication value according to the EN13487 standard parallel pipe. Goedhart uses the fan manufacturer's sound power level (LwA) at the inlet side of the fan. Changes to or by the fan or the product, affect the sound, in these cases, consult the manufacturer for the new indication value. In critical sound requirements, we advise you to consult an expert.

## Defrostsystem:

For room temperatures where ice build-up can be expected and where the coilblock can not be defrosted by the room air, electric or hotgas defrost is necessary.

With low temperatures we also advise fan periphery heating.

### Electrical defrost:

The Goedhart VRB and VRZ can be provided with electric defrost. A distinction can be made here between heavy defrost loads for low temperatures and light defrost load for higher temperatures (room temperature approximately 0 °C). The stainless steel heater elements are fitted in the coilblock in tubes, which forms a high conductive medium between the heaters and the fins. The driptray heaters are fitted to the underside of the aluminium inner tray with aluminium profiles. The heater elements which are rated for 220/240 V are connected for supply 380/415 V with neutral. The coilblock elements are removable from the end opposite to the refrigerant connections, whilst the tray heater elements can

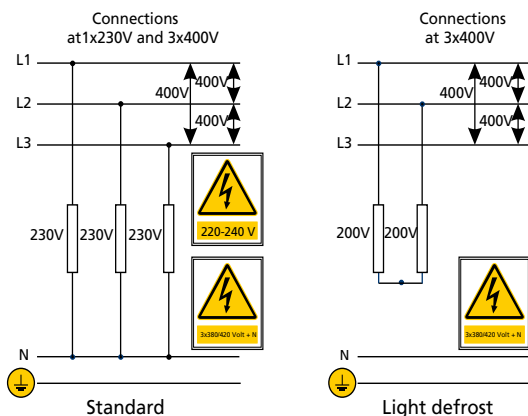

be removed once the outer tray has been taken off.

### Hot gas defrost:

The coil block is suited for hot gas defrost (hot gas supply through the suction header). At an extra price the driptray can be provided with a hotgas/cooling medium spiral. The stainless steel tubes of the hotgas spiral are enclosed in special aluminium profiles that are rigidly secured to the underside of the aluminium inner tray, thus providing a good bond for maximum heat transfer. Just as with electric defrost a distinction is made with hotgas defrost between light defrost load (room temperature about 0°C) and heavy defrost load.

## Accessories:

Standard accessories for the Goedhart VCI air coolers are:

- blow-through / draw-through air configuration
- Electric defrost, hot gas defrost and/or water defrost
- Fan periphery heating
- Hinged drip tray.
- Insulated drip tray
- Insulated hygienic polyester drip tray
- Goedhart VCI-Z supplied with bellmouth connection per fan for a longer air throw
- Goedhart VCI-B supplied with air diffusor for a longer air throw
- Goedhart VCI-B supplied with air diffusor with air operated damper to increase defrost efficiency (airvolume reduced to approx. 90% and capacity reduced to approx. 95%)

The accessories are included in the price list.

## Optional extras:

Various optional extras for the VCI are available, price and delivery upon request:

- Isulation disks
- Feet for floor mounting
- Coating of the coil block
- Fan hood
- Hinged fan plates
- 60 Hz motors
- EC-fans
- Single phase motors
- Coolants (glycol, water, etc.)
- Pump system
- Other casing materials
- Other fin spacings
- Sea water resistant fins

## Mounting and Maintenance

Goedhart VCI is delivered on a wooden frame. When on the frame, Goedhart VCI can be handled by forklift truck, which makes positioning and installation simple. Refer to our maintenance and installation manual.



# Fans

Because of the flexible construction of the Goedhart VCI air cooler, in principle it is possible to deliver with different fans. GEA Goedhart selected a standard fan range of Ziehl Abegg (we reserve the right to alter the manufacturer) which fit perfectly on the Goedhart VCI air coolers. The fans can be supplied in both blow-through and draw-through executions. Against an extra price and with extra delivery times stainless steel guards and EC-fans are available.

## Execution

The fans meet the ErP directive. The fans have very good aerodynamic features because of the special impeller geometry. This special impeller geometry gives the fan a low noise level and an high efficiency.

1x230V fans are suitable for a room temperature till -25°C. 3x400V fans are suitable for a room temperature till -40°C. When lower room temperatures are desired, special fans are need.

- Tension : 3x400V-50Hz-3 phase  
 : 1x230V-50Hz-1 phase  
 (60Hz execution on request)
- Protection class : IP44 / IP54
- Color : RAL9005 (black)
- Speed controlling : - 3 Phase motors are suitable for 2-speed regulation by  $\Delta$ -Y reconnection.  
 - 3 Phase motors are suitable for frequency controller with all-pole sinus filter.  
 - 1 Phase motors are suitable for phase control and transformer.

The motors are standard executed with a thermo contact (TB) and must be connected to prevent motor damages. The maximum allowable working data in the table and on the name plate of the fans are to operate in an air temperature of 20 °C (air density of  $\rho = 1,2 \text{ kg/m}^3$ ). For air temperatures lower then +20 °C, the current amperage can be calculated by using the diagram multiplication factor, suitable thermal overloads can then be selected.

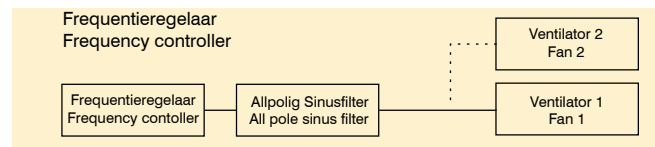
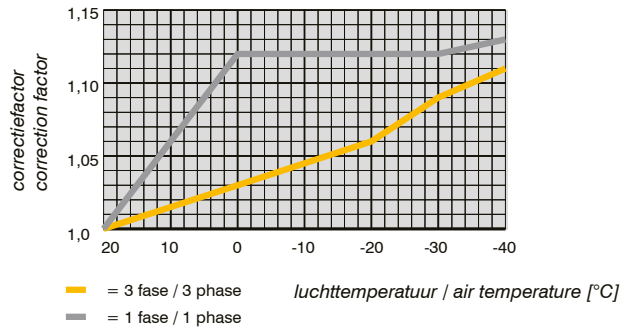

## Three phase - 50 Hz

Fan type	Tension V	$\Delta$				Y				Wiring diagram blow-through/ draw-through
		Speed min <sup>-1</sup>	Input Watt	FLC A	Sound power indication each fan LwA (+/-2dB(A)) dB(A)	Speed min <sup>-1</sup>	Input Watt	FLC A	Sound power indication each fan LwA (+/-2dB(A)) dB(A)	
<b>4 pole (n=1500 min<sup>-1</sup> nom.)</b>										
FN040	3x400/690	1370	230	0.44	76	1110	170	0.27	70,5	108B/108A
FN045	3x400/690	1250	350	0.64	78	950	220	0.35	70	108B/108A
FN050	3x400/690	1330	830	1.45	81	940	550	0.97	75	108B/108A
FN056	3x400/690	1280	1050	2.20	85	920	580	1.10	76	108B/108A
FE063	3x400/690	1330	1450	2.60	89	1080	980	1.60	84	108B/108A
<b>6 pole (n=1000 min<sup>-1</sup> nom.)</b>										
FN045	3x400/690	860	180	0.39	67	640	100	0.19	61	108B/108A
FN050	3x400/690	870	290	0.74	72	590	150	0.36	64	108B/108A
FN056	3x400/690	870	340	0.70	73	630	210	0.38	65	108B/108A
FN063	3x400/690	900	630	1.25	74	720	440	0.73	69	108B/108A

## Single phase - 50 Hz

Fan type	Speed min <sup>-1</sup>	Input Watt	FLC A	Sound power indication each fan LwA (+/-2dB(A)) dB(A)	Wiring diagram blow-through/ draw-through
<b>4 pole (n=1500 min<sup>-1</sup> nom.)</b>					
FN040	1350	240	1.10	76	104B/104A
FN045	1290	390	1.75	80	104B/104A
FN050	1230	750	3.35	81,5	104B/104A
<b>6 pole (n=1000 min<sup>-1</sup> nom.)</b>					
FN040	950	130	0.58	68	104B/104A
FN045	860	180	0.82	68,5	104B/104A
FN050	910	300	1.30	71,5	104B/104A

## Wiring diagram fans for blow-through air coolers

### Ziehl Abegg 1x230V-50Hz (104XB)

U1 = bruin  
 U2 = blauw  
 Z1 = zwart  
 Z2 = oranje  
 TB = wit

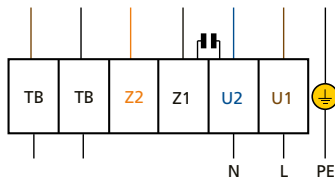

## Wiring diagram fans for draw-through air coolers

### Ziehl Abegg 1x230V-50Hz (104XA)

U1 = bruin  
 U2 = blauw  
 Z1 = zwart  
 Z2 = oranje  
 TB = wit

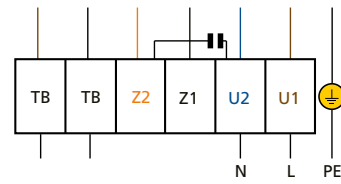

### Ziehl Abegg 3x400V (Δ)-50Hz (108XB)

U1 = bruin  
 V1 = blauw  
 W1 = zwart  
 U2 = rood  
 V2 = grijs  
 W2 = oranje  
 TB = wit

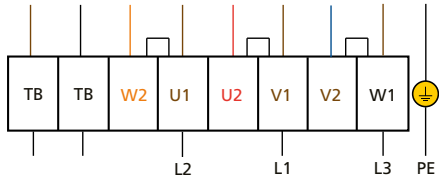

### Ziehl Abegg 3x400V (Δ)-50Hz (108XA)

U1 = bruin  
 V1 = blauw  
 W1 = zwart  
 U2 = rood  
 V2 = grijs  
 W2 = oranje  
 TB = wit

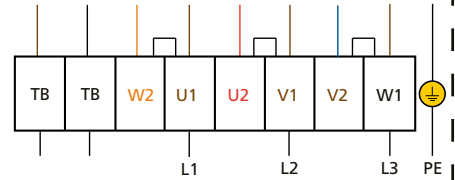

### Ziehl Abegg 3x400V (Y)-50Hz (108XB)

U1 = bruin  
 V1 = blauw  
 W1 = zwart  
 U2 = rood  
 V2 = grijs  
 W2 = oranje  
 TB = wit

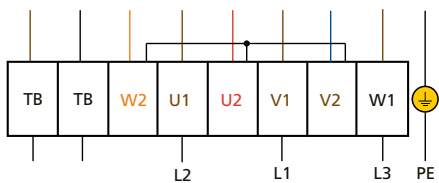

### Ziehl Abegg 3x400V (Y)-50Hz (108XA)

U1 = bruin  
 V1 = blauw  
 W1 = zwart  
 U2 = rood  
 V2 = grijs  
 W2 = oranje  
 TB = wit

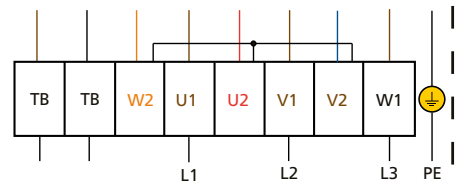

## Fan heating

To prevent the freezing of the impeller of the fan during the defrost cyclus of the air cooler, a fan heater can be used.

Fan diameter	Diameter element	Power (230V)
mm	D in mm	kW
400	435	0,50
450	485	0,63
500	535	0,63
560	595	0,76
630	665	0,89

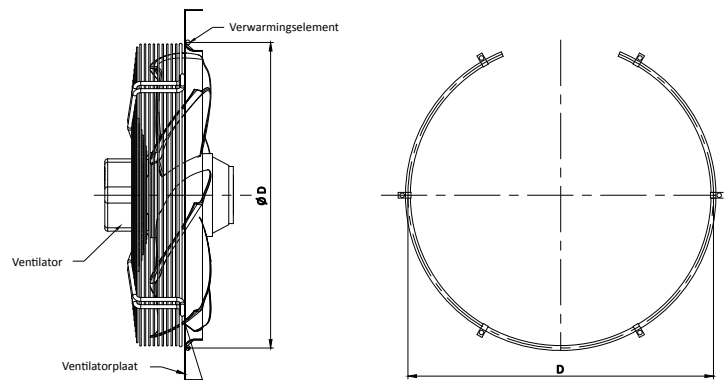

# Correction factors

## Correction factors DT1 (=air-on)

The capacities are based on R-404A direct expansion, DT1 and a RH of 85 %. DT1 is the difference between air-on temperature and the evaporation temperature of the cooler. The evaporation temperature is the saturate temperature corresponding to the pressure at the suction outlet of the cooler.

The nominal capacities:

- (SC1)  $t_o=0^{\circ}\text{C}$  and  $\text{DT1}=10\text{K}$
- (SC2)  $t_o=-8^{\circ}\text{C}$  and  $\text{DT1}=8\text{K}$
- (SC3)  $t_o=-25^{\circ}\text{C}$  and  $\text{DT1}=7\text{K}$

Correction factors for various air-on temperatures and temperature differences (DT1) are as indicated in the table below. The requested capacity must be multiplied by a correction factor from the table, so that a cooler with the resulting nominal capacity can be chosen from the selection tables.

$Q_{\text{nominal}} = \text{factor} \times Q_{\text{requested}}$

### Cooling

DT1	SC1-DT1 =10K-Air-on=10°C (0/+10)									
	Evaporation temperature (°C)									
K	+7	+6	+5	+4	+3	+2	+1	0	-1	-2
6	1,87	1,87	1,87	1,88	1,88	1,89	1,89	1,89	1,89	1,90
7	1,53	1,53	1,54	1,54	1,54	1,55	1,55	1,55	1,55	1,56
8	1,28	1,28	1,28	1,29	1,29	1,30	1,30	1,30	1,30	1,31
9	1,11	1,11	1,11	1,12	1,12	1,13	1,13	1,13	1,13	1,14
10	0,98	0,98	0,98	0,99	0,99	0,99	1,00	1,00	1,00	1,01
11	0,89	0,89	0,89	0,90	0,90	0,91	0,91	0,91	0,91	0,92
12	0,78	0,79	0,79	0,79	0,80	0,80	0,80	0,80	0,80	0,81

### Cooling / Freezing

DT1	SC2-DT1 =8K-Air-on=0°C (-8/0)									
	Evaporation temperature (°C)									
K	-3	-4	-5	-6	-7	-8	-9	-10	-11	-12
6	1,32	1,34	1,39	1,43	1,46	1,46	1,47	1,47	1,48	1,49
7	1,05	1,08	1,12	1,15	1,18	1,19	1,19	1,20	1,20	1,21
8	0,86	0,88	0,91	0,94	0,97	1,00	1,00	1,01	1,01	1,02
9	0,76	0,76	0,78	0,80	0,82	0,86	0,86	0,87	0,87	0,88
10	0,66	0,67	0,69	0,71	0,73	0,74	0,74	0,75	0,75	0,76
11	0,58	0,59	0,59	0,60	0,62	0,64	0,64	0,65	0,66	0,67
12	0,55	0,54	0,54	0,54	0,55	0,55	0,56	0,57	0,58	0,59

### Freezing

DT1	SC3-DT1 =7K-Air-on=-18°C (-25/-18)									
	Evaporation temperature (°C)									
K	-21	-22	-23	-24	-25	-26	-27	-28	-29	-30
6	1,20	1,20	1,21	1,21	1,22	1,22	1,23	1,23	1,24	1,24
7	0,99	0,99	0,99	1,00	1,00	1,00	1,01	1,01	1,02	1,02
8	0,83	0,84	0,84	0,84	0,85	0,85	0,85	0,85	0,86	0,86
9	0,72	0,72	0,72	0,73	0,73	0,73	0,73	0,74	0,74	0,74
10	0,63	0,63	0,63	0,64	0,64	0,64	0,64	0,65	0,65	0,65
11	0,56	0,56	0,56	0,57	0,57	0,57	0,50	0,58	0,58	0,58
12	0,50	0,51	0,51	0,51	0,51	0,51	0,52	0,52	0,52	0,52

### Calculation example

Fin spacing	: 6 mm	-	DT1 = +3- (+10) = 7K
Required capacity	: 30 kW	-	Correction factor = 1,54
Air-on temperature	: +10 °C	-	Multiply required capacity with correction factor.
Refrigeration temp.	: +3 °C		30 kW x 1,54 = 46,2 kW
Condition	: SC1		
Refrigerant	: R-404A	-	Select air cooler from the table (SC1 type VCI-B 63506=47,5 kW)

# Attention!





#### Moisture carry over from the coil block:

When you select VCI-B with a Ø500 mm fan in an application with a high relative humidity and/or defrost with room air, Goedhart advises the use of a fan with a low pitch angle or the draw-through execution VCI-Z. Thus, you will avoid the risk of moisture carry over from the coil block. The fan with a low pitch angle give a reducing of the capacity of approx. 5% and a reduction of the air volume of approx. 10%.

#### Air throw\*\* (only draw-through execution)

The air throw mentioned in the selection table indicated with \*\* is based on an air temperature of 20°C, blowing under a flat ceiling without any obstruction. The height and air circulation fold of the room can influence the air throw. The air speed at the end of the throw-length is 0,25 m/sec

# Goedhart VCI 7mm

Type VCI		3x400V-50Hz-4pole (1500 min <sup>-1</sup> nom.)					Dimensions											Connections				
		R404A			Air volume m <sup>3</sup> /h	LpA @ 3 m (+/- 2 dB(A))*	Surface m <sup>2</sup>	Internal volume dm <sup>3</sup>	Weight kg	L mm	B mm	H mm	C mm	E E1 mm	E2 mm	E3 mm	D1 mm	D2 mm	Refrigerant			
		DT1 = 10K (SC1) air on= 0°C (0/+10)	DT1 = 8K (SC2) air on= 0°C (-8/0)	DT1 = 7K (SC3) air on= -18°C (-25/-18)															In mm	Uit mm	Hot gas mm	Air throw** m
		kW	kW	kW	m <sup>3</sup> /h	dB(A)	m <sup>2</sup>	dm <sup>3</sup>	kg	mm	mm	mm	mm	mm	mm	mm	mm	mm	mm	mm	mm	mm
	4x	3.4.45.7	18,7	13,2	21372	61,3	91	23	220	3656	560	720	450	1628	1628		914	1828	16	28	35	22,5
	4.4.45.7	23,7	16,4	20717	61,3	122	30	247	3656	610	720	500	1628	1628		914	1828	16	35	35	22,5	
	6.4.45.7	30,9	21,9	19475	61,3	183	45	303	3656	710	720	600	1628	1628		914	1828	16	42	35	22,5	
	8.4.45.7	35,9	25,9	18372	61,3	244	60	360	3656	810	720	700	1628	1628		914	1828	16	42	35	22,5	
	3.4.50.7	25,2	17,4	29933	64,0	114	29	307	4456	680	720	550	2028	2028		1114	2228	16	35	35	25	
	4.4.50.7	31,5	21,9	29169	64,0	152	38	341	4456	730	720	600	2028	2028		1114	2228	16	42	35	25	
	6.4.50.7	41,6	29,5	27768	64,0	228	57	410	4456	830	720	700	2028	2028		1114	2228	16	42	35	25	
	8.4.50.7	48,7	35,2	26527	64,0	304	75	479	4456	930	720	800	2028	2028		1114	2228	22	42	35	25	
	3.4.56.7	36,1	24,4	42140	67,7	167	42	408	4856	780	920	650	2228	2228		1214	2428	16	42	35	27,5	
	4.4.56.7	41,5	30,0	41236	67,7	223	55	455	4856	830	920	700	2228	2228		1214	2428	16	42	35	27,5	
	6.4.56.7	60,6	41,9	39634	67,7	335	83	550	4856	930	920	800	2228	2228		1214	2428	22	54	42	27,5	
	8.4.56.7	68,8	45,1	38251	67,7	446	110	646	4856	1030	920	900	2228	2228		1214	2428	22	54	42	27,5	
3.4.63.7	47,0	32,7	51628	71,5	228	57	553	5256	795	1120	650	2428	2428		1314	2628	22	42	42	27,5		
4.4.63.7	58,8	41,3	50940	71,5	304	75	614	5256	845	1120	700	2428	2428		1314	2628	22	54	42	27,5		
6.4.63.7	78,5	55,6	49550	71,5	456	113	738	5256	945	1120	800	2428	2428		1314	2628	22	54	42	27,5		
8.4.63.7	91,5	66,5	48186	71,5	608	150	863	5256	1045	1120	900	2428	2428		1314	2628	28	54	42	27,5		
	5x	3.5.45.7	26,4	18,2	27443	62,1	137	29	267	4456	560	720	450	1628	2428		1114	2228	16	35	35	22,5
	4.5.45.7	29,6	20,8	25894	62,1	152	38	302	4456	610	720	500	1628	2428		1114	2228	16	35	35	22,5	
	6.5.45.7	38,4	27,6	24340	62,1	228	57	372	4456	710	720	600	1628	2428		1114	2228	16	42	35	22,5	
	8.5.45.7	45,0	32,3	22961	62,1	304	75	441	4456	810	720	700	1628	2428		1114	2228	16	42	35	22,5	
	3.5.50.7	30,4	22,0	37414	64,7	143	36	376	5456	680	720	550	2028	3028		1364	2728	16	42	35	25	
	4.5.50.7	38,5	27,5	36459	64,7	190	47	417	5456	730	720	600	2028	3028		1364	2728	16	42	35	25	
	6.5.50.7	51,7	36,2	34707	64,7	285	71	503	5456	830	720	700	2028	3028		1364	2728	22	54	42	25	
	8.5.50.7	61,7	42,3	33156	64,7	380	94	589	5456	930	720	800	2028	3028		1364	2728	22	54	42	25	
	3.5.63.7	58,8	41,1	64535	72,1	285	71	677	6456	795	1120	650	2428	2428	1200	1076	2x2152	22	54	42	27,5	
	4.5.63.7	73,7	51,7	63672	72,1	380	94	754	6456	845	1120	700	2428	2428	1200	1076	2x2152	22	54	42	27,5	
	6.5.63.7	97,9	69,5	61935	72,1	570	141	907	6456	945	1120	800	2428	2428	1200	1076	2x2152	28	64	42	27,5	
	8.5.63.7	117,2	83,1	60227	72,1	760	187	1063	6456	1045	1120	900	2428	2428	1200	1076	2x2152	28	64	42	27,5	
	6x	3.6.45.7	28,2	19,8	32055	62,6	137	34	315	5256	560	720	450	2428	2428		1314	2628	16	35	35	22,5
	4.6.45.7	35,4	24,4	31071	62,6	183	45	357	5256	610	720	500	2428	2428		1314	2628	16	42	35	22,5	
	6.6.45.7	46,7	31,9	29205	62,6	274	68	439	5256	710	720	600	2428	2428		1314	2628	16	42	35	22,5	
	8.6.45.7	54,6	38,1	27550	62,6	365	90	523	5256	810	720	700	2428	2428		1314	2628	22	54	35	22,5	
	3.6.50.7	38,0	26,3	44895	65,2	171	43	444	6456	680	720	550	2028	2028	2000	1076	2x2152	16	42	35	25	
	4.6.50.7	47,5	33,1	43749	65,2	228	57	494	6456	730	720	600	2028	2028	2000	1076	2x2152	16	42	35	25	
	6.6.50.7	62,6	44,2	41646	65,2	342	85	595	6456	830	720	700	2028	2028	2000	1076	2x2152	22	54	42	25	
	8.6.50.7	73,3	52,8	39784	65,2	456	113	696	6456	930	720	800	2028	2028	2000	1076	2x2152	22	54	42	25	
	3.6.63.7	70,0	49,6	77442	72,6	342	85	803	7656	795	1120	650	2428	2428	2400	1276	2x2552	22	54	42	27,5	
	4.6.63.7	88,2	59,5	76405	72,6	456	113	894	7656	845	1120	700	2428	2428	2400	1276	2x2552	22	54	42	27,5	
	6.6.63.7	118,3	82,7	74321	72,6	684	169	1077	7656	945	1120	800	2428	2428	2400	1276	2x2552	28	64	42	27,5	
	8.6.63.7	141,1	97,6	72270	72,6	912	225	1262	7656	1045	1120	900	2428	2428	2400	1276	2x2552	28	64	42	27,5	
	7x	3.7.45.7	33,2	23,5	37397	63,0	160	40	363	6056	560	720	450	2428	2428	800	1514	3028	16	42	35	22,5
	4.7.45.7	41,0	29,3	36249	63,0	213	53	409	6056	610	720	500	2428	2428	800	1514	3028	16	42	35	22,5	
	6.7.45.7	52,8	38,4	34070	63,0	319	79	505	6056	710	720	600	2428	2428	800	1514	3028	22	54	42	22,5	
	8.7.45.7	62,7	44,6	32140	63,0	426	105	600	6056	810	720	700	2428	2428	800	1514	3028	22	54	42	22,5	
	3.7.63.7	82,0	57,6	90349	73,2	399	99	899	7456	795	1320	650	2028	2028	800	1243	2x2485	22	54	42	27,5	
	4.7.63.7	103,3	72,3	89139	73,2	532	131	1002	7456	845	1320	700	2028	2028	3000	1243	2x2485	28	64	42	27,5	
	6.7.63.7	138,3	95,9	86708	73,2	798	197	1209	7456	945	1320	800	2028	2028	3000	1243	2x2485	28	64	42	27,5	
	8.7.63.7	164,6	114,8	84317	73,2	1064	262	1418	7456	1045	1320	900	2028	2028	3000	1243	2x2485	28	76	42	27,5	
	8x	3.8.45.7	38,4	26,3	42737	63,4	182	45	410	6856	560	720	450	2428	2428	1600	1143	2x2285	16	42	35	22,5
	4.8.45.7	47,8	33,1	41425	63,4	243	60	464	6856	610	720	500	2428	2428	1600	1143	2x2285	16	42	35	22,5	
	6.8.45.7	62,4	43,8	38936	63,4	365	90	573	6856	710	720	600	2428	2428	1600	1143	2x2285	22	54	42	22,5	
	8.8.45.7	72,1	51,7	36729	63,4	487	120	682	6856	810	720	700	2428	2428	1600	1143	2x2285	22	54	42	22,5	

\* = Sound pressure indication (LpA) at 3 m distance each air cooler (+/- 2 dB(A)), free field conditions, according EN13487

\*\* = Air throw see remark page 5







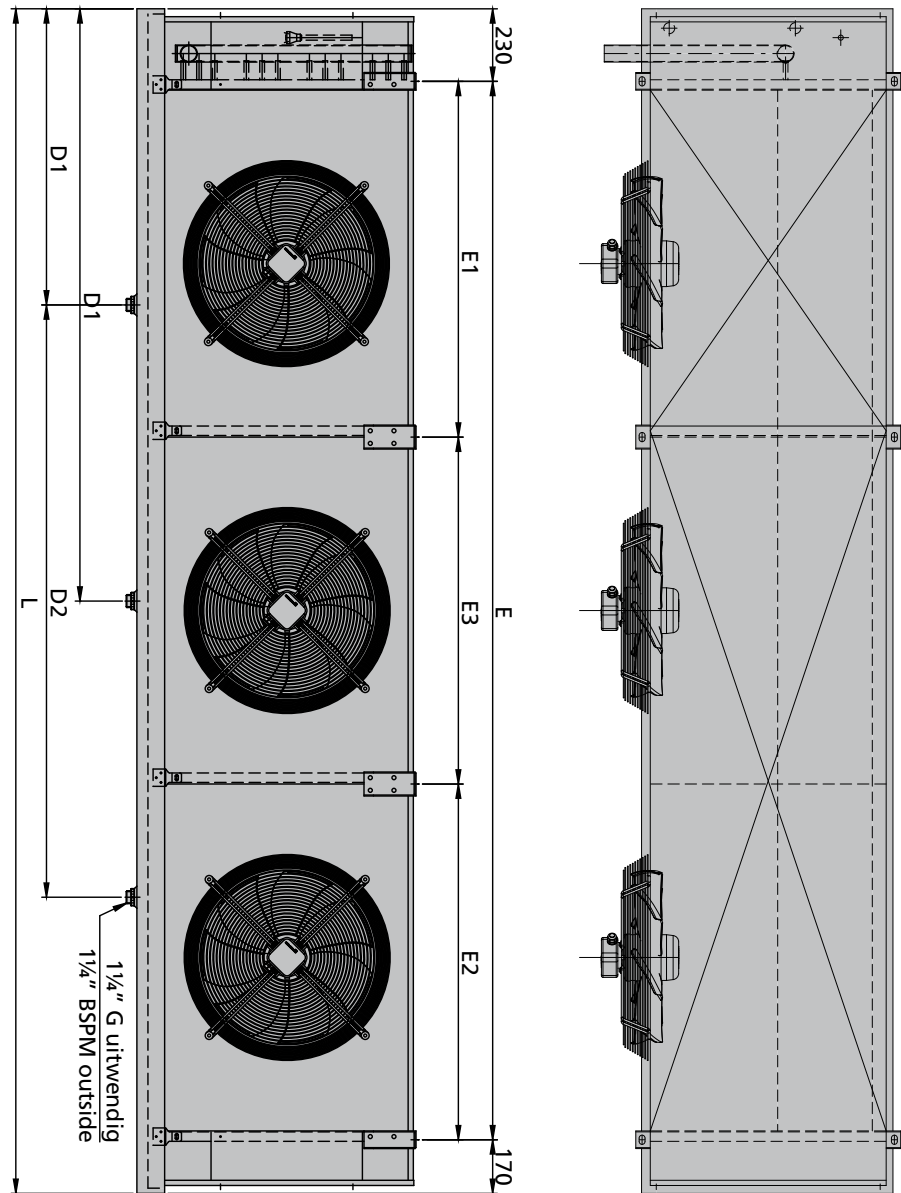
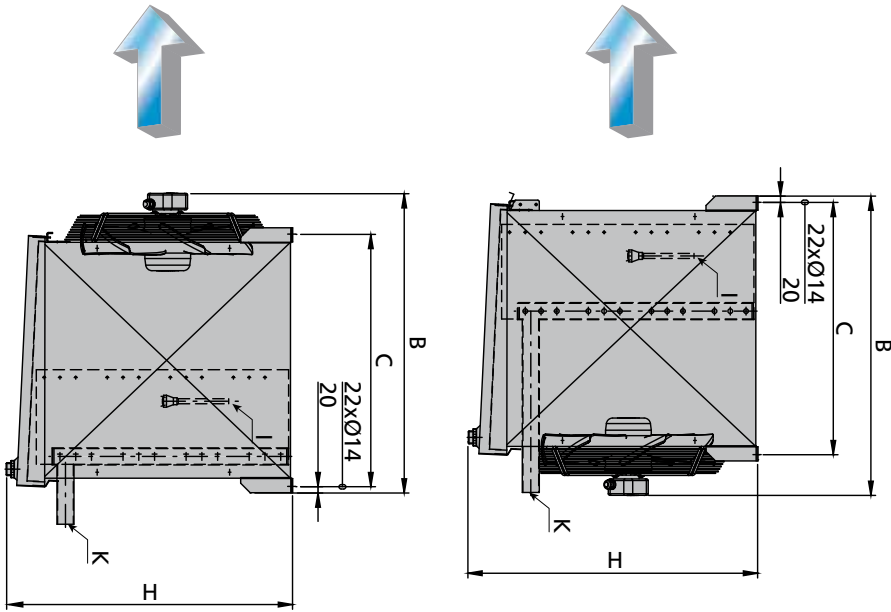

For moisture carry over see remark pag 5

Capacities and air volumes with 60 Hz fans on request or in our GPC selection program available.

# Goedhart VCI Drawing



# Goedhart VCI Electrical defrost

Type VC	Light defrost								Heavy defrost*									
	Coil block 			Drip tray 				Total each air cooler	Coil block 			Drip tray 				Total each air cooler		
	Number	Type of heating element	Total	Number	Type of heating element	Tension	Total		Number	Type of heating element	Total	Number	Type of heating element	Tension	Total			
	n	mm	kW	n	mm	V	kW	kW	n	mm	kW	n	mm	V	kW	kW		
	3.4.45.f	4	3400	5,68	2	4000	200	2,54	8,22	6	3400	8,52	4	4000	200	5,08	13,6	
	4.4.45.f	4	3400	5,68	2	4000	200	2,54	8,22	6	3400	8,52	4	4000	200	5,08	13,6	
	6.4.45.f	6	3400	8,52	2	4000	200	2,54	11,06	8	3400	11,36	4	4000	200	5,08	16,44	
	8.4.45.f	8	3400	11,36	2	4000	200	2,54	13,9	12	3400	17,04	4	4000	200	5,08	22,12	
	1.4.45.f	8	3400	11,36	4	4000	200	5,08	16,44	12	3400	17,04	4	4000	200	5,08	22,12	
	3.4.50.f	4	4300	7,24	2	4600	200	2,92	10,16	6	4300	10,86	4	4600	200	5,84	16,7	
	4.4.50.f	4	4300	7,24	2	4600	200	2,92	10,16	6	4300	10,86	4	4600	200	5,84	16,7	
	6.4.50.f	6	4300	10,86	2	4600	200	2,92	13,78	8	4300	14,48	4	4600	200	5,84	20,32	
	8.4.50.f	8	4300	14,48	2	4600	200	2,92	17,4	12	4300	21,72	4	4600	200	5,84	27,56	
	1.4.50.f	8	4300	14,48	4	4600	200	5,84	20,32	12	4300	21,72	4	4600	200	5,84	27,56	
	3.4.56.f	6	4600	11,64	2	5200	200	3,34	14,98	8	4600	15,52	4	5200	200	6,68	22,2	
	4.4.56.f	6	4600	11,64	2	5200	200	3,34	14,98	8	4600	15,52	4	5200	200	6,68	22,2	
	6.4.56.f	8	4600	15,52	2	5200	200	3,34	18,86	12	4600	23,28	4	5200	200	6,68	29,96	
	8.4.56.f	12	4600	23,28	4	5200	200	6,68	29,96	16	4600	31,04	4	5200	200	6,68	37,72	
1.4.56.f	12	4600	23,28	4	5200	200	6,68	29,96	16	4600	31,04	4	5200	200	6,68	37,72		
3.4.63.f	10	5200	22	2	5500	200	3,52	25,52	12	5200	26,4	4	5500	200	7,04	33,44		
4.4.63.f	10	5200	22	2	5500	200	3,52	25,52	12	5200	26,4	4	5500	200	7,04	33,44		
6.4.63.f	10	5200	22	2	5500	200	3,52	25,52	12	5200	26,4	4	5500	200	7,04	33,44		
8.4.63.f	14	5200	30,8	4	5500	200	7,04	37,84	18	5200	39,6	4	5500	200	7,04	46,64		
1.4.63.f	14	5200	30,8	4	5500	200	7,04	37,84	18	5200	39,6	4	5500	200	7,04	46,64		
	3.5.45.f	4	4300	7,24	2	4600	200	2,92	10,16	6	4300	10,86	4	4600	200	5,84	16,7	
	4.5.45.f	4	4300	7,24	2	4600	200	2,92	10,16	6	4300	10,86	4	4600	200	5,84	16,7	
	6.5.45.f	6	4300	10,86	2	4600	200	2,92	13,78	8	4300	14,48	4	4600	200	5,84	20,32	
	8.5.45.f	8	4300	14,48	2	4600	200	2,92	17,4	12	4300	21,72	4	4600	200	5,84	27,56	
	1.5.45.f	8	4300	14,48	4	4600	200	5,84	20,32	12	4300	21,72	4	4600	200	5,84	27,56	
	3.5.50.f	4	5200	8,8	2	5500	200	3,52	12,32	6	5200	13,2	4	5500	200	7,04	20,24	
	4.5.50.f	4	5200	8,8	2	5500	200	3,52	12,32	6	5200	13,2	4	5500	200	7,04	20,24	
	6.5.50.f	6	5200	13,2	2	5500	200	3,52	16,72	8	5200	17,6	4	5500	200	7,04	24,64	
	8.5.50.f	8	5200	17,6	2	5500	200	3,52	21,12	12	5200	26,4	4	5500	200	7,04	33,44	
	1.5.50.f	8	5200	17,6	4	5500	200	7,04	24,64	12	5200	26,4	4	5500	200	7,04	33,44	
	3.5.63.f	10	6400	27,6	2	6700	200	4,38	31,98	12	6400	33,12	4	6700	200	8,76	41,86	
	4.5.63.f	10	6400	27,6	2	6700	200	4,38	31,98	12	6400	33,12	4	6700	200	8,76	41,86	
	6.5.63.f	10	6400	27,6	2	6700	200	4,38	31,98	12	6400	33,12	4	6700	200	8,76	41,86	
	8.5.63.f	14	6400	38,6	4	6700	200	8,76	47,36	18	6400	49,68	4	6700	200	8,76	58,46	
1.5.63.f	14	6400	38,6	4	6700	200	8,76	47,36	18	6400	49,68	4	6700	200	8,76	58,46		
	3.6.45.f	4	5200	8,8	2	5500	200	3,52	12,32	6	5200	13,2	4	5500	200	7,04	20,24	
	4.6.45.f	4	5200	8,8	2	5500	200	3,52	12,32	6	5200	13,2	4	5500	200	7,04	20,24	
	6.6.45.f	6	5200	13,2	2	5500	200	3,52	16,72	8	5200	17,6	4	5500	200	7,04	24,64	
	8.6.45.f	8	5200	17,6	2	5500	200	3,52	21,12	12	5200	26,4	4	5500	200	7,04	33,44	
	1.6.45.f	8	5200	17,6	4	5500	200	7,04	24,64	12	5200	26,4	4	5500	200	7,04	33,44	
	3.6.50.f	4	6100	10,4	2	6400	200	4,16	14,56	6	6100	15,6	4	6400	200	8,32	23,92	
	4.6.50.f	4	6100	10,4	2	6400	200	4,16	14,56	6	6100	15,6	4	6400	200	8,32	23,92	
	6.6.50.f	6	6100	15,6	2	6400	200	4,16	19,76	8	6100	20,8	4	6400	200	8,32	29,12	
	8.6.50.f	8	6100	20,8	2	6400	200	4,16	24,96	12	6100	31,2	4	6400	200	8,32	39,52	
	1.6.50.f	8	6100	20,8	4	6400	200	8,32	29,12	12	6100	31,2	4	6400	200	8,32	39,52	
	3.6.63.f	10	7600	33,1	2	7900	200	5,26	38,36	12	7600	39,7	4	7900	200	10,52	50,22	
	4.6.63.f	10	7600	33,1	2	7900	200	5,26	38,36	12	7600	39,7	4	7900	200	10,52	50,22	
	6.6.63.f	10	7600	33,1	2	7900	200	5,26	38,36	12	7600	39,7	4	7900	200	10,52	50,22	
	8.6.63.f	14	7600	46,3	4	7900	200	10,52	56,82	18	7600	59,6	4	7900	200	10,52	70,12	
1.6.63.f	14	7600	46,3	4	7900	200	10,52	56,82	18	7600	59,6	4	7900	200	10,52	70,12		
	3.7.45.f	4	5800	9,84	2	6400	200	4,16	14,00	6	5800	14,76	4	6400	200	7,84	22,6	
	4.7.45.f	4	5800	9,84	2	6400	200	4,16	14,00	6	5800	14,76	4	6400	200	7,84	22,6	
	6.7.45.f	6	5800	14,76	2	6400	200	4,16	18,92	8	5800	19,68	4	6400	200	7,84	27,52	
	8.7.45.f	8	5800	19,68	2	6400	200	4,16	23,84	12	5800	29,52	4	6400	200	7,84	37,36	
	1.7.45.f	8	5800	19,68	4	6400	200	8,32	28,00	12	5800	29,52	4	6400	200	7,84	37,36	
	3.7.63.f	12	7300	38,0	2	7600	200	5,00	43,00	14	7300	44,4	4	7600	200	10,00	54,40	
	4.7.63.f	12	7300	38,0	2	7600	200	5,00	43,00	14	7300	44,4	4	7600	200	10,00	54,40	
	6.7.63.f	12	7300	38,0	2	7600	200	5,00	43,00	14	7300	44,4	4	7600	200	10,00	54,40	
	8.7.63.f	16	7300	50,7	4	7600	200	10,00	60,70	18	7300	57,0	4	7600	200	10,00	67,00	
	1.7.63.f	16	7300	50,7	4	7600	200	10,00	60,70	18	7300	57,0	4	7600	200	10,00	67,00	
		3.8.45.f	4	6700	11,56	2	7000	200	4,58	16,14	6	6700	17,34	4	7000	200	9,16	26,50
		4.8.45.f	4	6700	11,56	2	7000	200	4,58	16,14	6	6700	17,34	4	7000	200	9,16	26,50
		6.8.45.f	6	6700	17,34	2	7000	200	4,58	21,92	8	6700	23,12	4	7000	200	9,16	32,28
		8.8.45.f	8	6700	23,12	2	7000	200	4,58	27,7	12	6700	34,68	4	7000	200	9,16	43,84
1.8.45.f		8	6700	23,12	4	7000	200	9,16	32,28	12	6700	34,68	4	7000	200	9,16	43,84	

f = Fin spacing

\* = Always heavy electric defrost when using cooling mediums.



Excellence

Passion

Integrity

Responsibility

GEA-versity

GEA Group is a global mechanical engineering company with multi-billion euro sales and operations in more than 50 countries. Founded in 1881 the company is one of the largest providers of innovative equipment and process technology. GEA Group is listed in the STOXX Europe 600 Index.



## GEA Heat Exchangers

GEA Goedhart B.V.

Nijverheidsweg 6, 4695 RC Sint Maartensdijk  
The Netherlands  
Phone +31 (0)166 665 665, Fax+31 (0)166 663 698  
[www.goedhart.nl](http://www.goedhart.nl),  
[info.goedhart.nl@geagroup.com](mailto:info.goedhart.nl@geagroup.com)

## GEA Heat Exchangers

GEA Goedhart s.r.o.

Kostomlátecká 180, 288 26 Nymburk  
Czech Republic  
Phone +420 325 519 951, Fax+420 325 519 952  
[www.goedhart.cz](http://www.goedhart.cz),  
[goedhart.cz@geagroup.com](mailto:goedhart.cz@geagroup.com)